

Appendix 1: Definitions

Table A 1

“AC”	means alternating current;
“ACC”	means area Control Centre;
“Act”	means the Electric Power Sector Reform Act, 2001, as amended;
“Active Power”	means the product of voltage and the in-phase component of alternating current measured in units of Watts and standard multiples thereof; 1000 Watts = 1 kW 1000 kW = 1 MW 1000 MW = 1 GW 1000 GW = 1 TW
“AGC Regulation”	means the Ancillary Service provided by a Generating Unit equipped with Automatic Generation Control;
“AGC”	means Automatic Generation Control;
“Agreements”	has the meaning assigned to that term in the Market Rules;
“Ancillary Service Agreement”	means the bilateral agreement to provide an Ancillary Service;
“Ancillary Service”	means a service, other than the primary production of electricity, which is used to operate a stable and secure Power System including but not limited to: Reactive Power, Operating Reserve, Frequency Control and Black Start Capability;
“Apparatus”	means all TSP equipment, or User equipment, as the case may be, in which electrical conductors are used, supported or which they form a part.
“Applicable Reliability Criteria”	means the Reliability criteria that will ensure that the Power System development conforms to minimum planning criteria;
“ARC”	means automatic recloser;
“Area Control Error (ACE)”	means the instantaneous difference between actual and scheduled interchange, taking into account the effects

of Frequency bias (and time error or unilateral inadvertent if automatic correction for either is part of the system's AGC);

“Automatic Generation Control (“AGC”)”	means the process whereby electronic equipment automatically adjusts a Control Area’s Generation from a central location to maintain its Interchange Transaction Schedule plus Frequency bias;
“Automatic Voltage Regulator”	means a continuously acting automatic closed loop control system acting on the excitation system so as to maintain a Generating Unit's terminal voltage at a desired set point;
“Auxiliary”	means any item of plant and/or apparatus not directly a part of the boiler plant or Generating Unit, but required for the boiler plant's or Generating Unit's functional operation. 'Auxiliary' shall be defined accordingly;
“Availability”	means a measure of the time a Generating Unit, transmission line or other Facility as the case may be is capable of delivering Energy to the Transmission System at the delivery point or of providing Ancillary Services to the Transmission System and the terms “Available” shall be construed accordingly;
“AVR”	means Automatic Voltage Regulator;
“Black Start Capability”	means the capability of a Power Station to commence operation without an outside Energy supply so as to energise a defined position of a TCN controlled grid;
“Black Start Station”	means a Power Station, which has Black Start Capability;
“Black Start”	means the procedure necessary for a recovery from a Total Shutdown or Partial Shutdown;
“Bulk Power Curtailment Index”	Energy means the sum of load (MW) lost multiplied by the frequency of such an event, divided by the actual amount of load (MW) in the Power System. Given in equivalent number of Shutdowns per year;
Capability Curve	means a capability chart, which shows the MW and MVAR capability limits within which a Generating Unit will be expected to operate under steady state

	conditions.
“Cautious Notice”	A notice conveying a warning against interference.
“CCGT”	Combine Cycle Gas Turbine. A generating unit comprising one or more gas turbine units (or other gas based units) and one or more team units where in normal operation, the waste heat from the gas turbine is passed to the water/steam system of the associated steam unit(s) directly connected to the hot gas line which enable those units to contribute to improve efficiency of the combined cycle operation of the module.
“Code”	means this Code, (including the Appendices) as amended from time to time, and approved by the Commission, in accordance with the Market Rules;
“Commission” or “NERC”	has the meaning assigned to that term in the Act;
“Condition”	means a specific provision in this Code;
“Conditions Precedent”	has the meaning assigned to that term in the Market Rules;
“Confidential Information”	has the meaning assigned to that term in the Market Rules;
“Connection Point”	means the physical point when the Participant’s plant is joined to the Transmission System;
“Customers Connected to the Transmission System”	means a customer which is directly connected to the transmission system
“Contracted Imbalance Quantities”	has the meaning assigned to that term in the Market Rules;
“Control Area Operator”	means the party responsible for operation of the Control Area;
“Control Action”	means any action required by the System Operator or TSP in controlling the Transmission System securely;
“Control Area”	means a Power System with Interconnections that is capable of maintaining continuous balance between the generation under its control, the consumption of electricity in the Control Area and the scheduled interchange with other Control Areas. The Nigerian Power System forms one Control Area;

“Control Centre”	means the centre responsible to monitor and to operate the applicable network;
“CT”	means current transformer;
“Customer Damage Function (CDF)”	means the variation of a customer’s perception with regard to the worth of service Reliability as a function of interruption duration;
“Day-ahead Nomination”	has the meaning assigned to that term in the Market Rules;
“Day-ahead Price”	has the meaning assigned to that term in the Market Rules;
“DC”	means direct current;
“Demand”	means the rate at which electric Energy is delivered to or by the System or part of the System comprising of both Active and Reactive Power, unless otherwise stated;
“Demand Control”	means all or any of the methods of achieving a Demand reduction or an increase in Demand;
“Demand Forecast”	means an estimate of future Demand typically worked out by using mathematical forecasting techniques and historical Demand data, weather forecasts and other pertinent information;
“Desynchronise”	means the process of taking a Generating Unit off a Power System to which it has been Synchronised, by opening any circuit breaker, and like terms shall be construed accordingly;
“Dispatch”	means the process by which the System Operator directs the operation of the Facility to cause a specified amount of Energy or Ancillary Services to be provided to or taken off the System Operator Controlled Grid. Inclusive of curtailment of Demand and Interchange Transaction Schedules in real time, to relieve congestion, to maintain the Reliability of the System Operator Controlled Grid and to comply with Applicable Reliability Criteria, as more particularly described in the Grid Code;
“Dispatch Day”	has the meaning assigned to that term in the Market Rules;

“Dispatch Instruction”	means the physical operating instruction issued by the System Operator to a Generating Unit for its Dispatch in accordance with the Grid Code;
“Dispatch Period”	has the meaning assigned to that term in the Market Rules;
“Dispatch Schedule”	means the schedule developed by the System Operator in accordance with the Grid Code for a Dispatch Period not later than two hours prior to the commencement of the relevant Dispatch Period;
“Distribution Embedded Unit”	has the meaning assigned to that term in the Market Rules;
“Distribution Network”	means all electric lines used for Distribution of Energy to final consumers and include any structures and equipment used for that purpose;
“Distribution System”	means all equipment, apparatus and structures used for Distribution of Energy to final consumers.
“Distribution”	means conveying Energy at voltages of less than 132kV;
“Distributor”	means a Participant who is licensed to distribute electricity under Part V section [64] of the Act;
“Eligible Customer”	has the meaning assigned to that term in the Act;
“Emergency Generation”	means the short-term generation of the plant above its rated capacity;
“EMS”	means Energy Management System;
“Energy”	has the meaning assigned to that term in the Market Rules;
“Equipment”	Any machinery, apparatus (stand alone or connected) that forms part of a System or sub System involve in production, transportation and consumption of electricity;
“ESI”	means Electricity Supply Industry;
“Expected Unserved Energy”	means the sum of Energy lost due to system unreliability and is measured in MWh per annum;
“Facility”	has the meaning assigned to that term in the Market Rules;
“Fault Level”	means prospective current that would flow into a short

	circuit at a stated point on the System and which may be expressed in kA or, if referred to a particular voltage, in MVA;
“Final Stage”	has the meaning assigned to that term in the Market Rules;
“Flicker”	means impression of unsteadiness of visual sensation induced by a light stimulus whose luminance or spectral Distribution fluctuates with time;
“Force Majeure”	has the meaning assigned to that term in the Market Rules;
“Forced Outage”	means an unanticipated intentional or automatic removal from service of, the temporary de-rating of, restriction of use of, or reduction in performance of equipment;
“Frequency Control”	means the retention of the Frequency on the Power System within acceptable limits;
“Frequency”	means the number of alternating current cycles per second (expressed in Hertz) at which a System is running;
Gas Turbine Unit	A Generating Unit driven by a gas turbine (e.g. an aero-engine).
“Generate and Generation”	has the meaning assigned to that term in the Market Rules;
“GRC”	Generator registered Capacity
“Generating Unit”	Any apparatus or equipment which produces electricity, including, for the avoidance of doubt, a CCGT unit.
“Generator”	A person or corporate entity who produces electricity under licence or exemption under the Electric Power Sector Reform Act, 2005 or its successor Act.
“GM”	means General Manager;
“Good Utility Practice”	means any of the international practices, methods and acts engaged in or approved by a significant portion of the electric utility industry during the relevant time period and under similar conditions as exist in Nigeria, or any of the practices, methods and acts in which, in the exercise of reasonable judgement in light of the

faith known at the time the decision was made, could have been expected to accomplish the desired result at a reasonable cost consistent with good business practice, Reliability, safety and expedition; however for the sake of clarity, it is not intended that the item Good Utility Practice be limited to optimum practice, method or act to the exclusion of all others, but rather than intention is to refer to acceptable practices, methods or acts internationally;

“Governor Control System”	means a self-correcting system that will adjust Active Power output of a Generating Unit , in response to a change in System Frequency, such that the Generating Unit assists in the recovery to Target Frequency;
“Governor Droop”	means the percentage steady state drop in the Frequency that would cause the Generating Unit under free governor action to change it’s output from zero to stated capacity;
“Grid Code”	means this Code as defined in the Act, , as amended from time to time, and approved by the Commission, in accordance with the Market Rules;
“Grid Connection Agreement”	has the meaning assigned to that term in the Market Rules;
“Harmonics”	means sinusoidal currents with a Frequency equal to an integer multiple of the fundamental Frequency of the connection voltage;
“High Voltage”	means a voltage, used for the supply of electricity, whose lower limit of nominal root-mean-square value is greater than 132kV;
“Hot Line”	means a direct voice line between two locations which are 100 % of the time available and not subject to any switching via the communication switch network;
“HQ”	means Head Quarters;
“HV”	means High Voltage;
“Hz”	means Hertz (Frequency);
“IEC”	means International Electro technical Commission;
“Imbalance Energy”	has the meaning assigned to that term in the Market Rules;

“Instructed Quantities”	Imbalance	has the meaning assigned to that term in the Market Rules;
“Interconnection Agreement”		has the meaning assigned to that term in the Market Rules;
“Interconnection”		has the meaning assigned to that term in the Market Rules;
“Interconnector Entitlement”	Capacity	has the meaning assigned to that term in the Market Rules;
“Interconnector Nomination”	Energy Trade	has the meaning assigned to that term in the Market Rules;
“Interrupted Assessment Rate (IEAR)”	Energy	means the factor that relates the customer losses caused by electric power interruptions to the worth of electric service Reliability,
“Interruptible Load”		means a portion or a combination of a Distributor Load or an Eligible Customer Load that can be interrupted or reduced by remote control or on instruction from the System Operator pursuant to a contract between such Distributor or Eligible Customer and the TCN;
“Invoices”		has the meaning assigned to that term in the Market Rules;
“kV”		means kilovolt;
“kVA”		means kilovolt-ampere;
“Load”		means the amount of electric power delivered or required at any specified point or points on a System;
“Load Factor”		means the ratio of the actual electrical Energy produced by a Generating Unit to the possible maximum electrical Energy that could be produced by that Generating Unit in any defined period;
“Load Shedding Severity Index”		means the annual expected duration of full load curtailment and is measured in minutes;
“Low Voltage”		means a voltage, used for the supply of electricity, whose upper limit of nominal root-mean-square value is 1kV;
“LV”		means Low Voltage;
“Market Rules”		means the electricity market rules as defined in the Act, as amended from time to time, and approved by the

	Commission;
“Medium Term Stage”	has the meaning assigned to that term in the Market Rules;
“Medium Voltage”	means a voltage, used for the supply of electricity, whose nominal root-means-square value lies between 1kV and 132kV;
“Meter Data”	has the meaning assigned to that term in the Market Rules;
“Meter Quantity”	has the meaning assigned to that term in the Market Rules;
“Meter”	means a device that measures and registers the integral active Energy or Reactive Power over a Dispatch Period and may include a data recorder, but shall be deemed to exclude instrument transformers;
“Metered Value”	means a measured electrical quantity that may be collected by telemetering, SCADA, or other means;
“Metering Installation”	means any apparatus used to measure the Energy flowing through a specified point in the System Operator Controlled Grid, which provides remote access to Meter Data and which may provide remote monitoring of equipment conditions, including Meters, instrument transformers, secondary circuitry, secondary devices, meter data services, related communication Facilities and related local equipment;
“Metering Point”	means the point in the Power System designated between two Users where the Energy Meters are located to meter the Energy exchanged between the two parties. Typically the Metering Point is the same as the Connection Point, but it could be different due to physical constraints;
“MVA”	means megavolt-ampere;
“MVA _r ”	means megavar (1,000,000 vars), the unit for Reactive Power;
“MVA _{rh} ”	means megavar hour;
“MW”	means megawatt (1,000,000 watts), the unit for Active Power;
“MWh”	means megawatt hour;

“National Control Centre (NCC)”	means the national Control Centre of the Nigerian Transmission System;
“NITEL”	means Nigeria Telecommunication Company;
“Node”	means the busbars at the end terminal of a breach of the System Operator Controlled Grid;
“Nomination”	has the meaning assigned to that term in the Market Rules;
“Normal Regulating Margin”	means the minimum on-line capacity that can be increased or decreased to allow the system to respond to all reasonable Demand changes;
“NNPC”	means the Nigerian National Petroleum Company;
“N-1 Criteria”	means that a system is sufficiently reliable if it is able to operate acceptably under any unplanned outage of equipment due to a single cause;
“Operating Reserve”	means the unused capacity above System Demand, which is required to cater for regulation, short-term Load forecasting errors, and unplanned plant Outages. It consists of Spinning Reserve, Quick Reserve and Slow Reserve;
“Operating Reserve Policy”	means the document prepared by the System Operator and approved by NERC which specifies the permissible mix of different types of reserve that will be used during the dispatch and real time operation.
“Operating Security”	means the ability of a Power System to withstand or limit the adverse effects of any credible contingency to the system including overloads beyond emergency ratings, excessive or inadequate voltage, and loss of stability or abnormal Frequency deviations;
“Operating State”	means any or all of the states as defined in Condition 9.2 of this Code;
“Operational Planning”	means all those actions as defined in section 10 and Sub Conditions of this Code;
“Outage”	means the removal of equipment from service, unavailability for connection of Equipment or temporary de-rating, restriction of use or reduction performance of equipment for any reason including, but not limited to, to permit the performance of inspections, tests or repairs on Equipment, and shall

	include a Planned Outage and a Forced Outage;
“Partial Shutdown”	means that there is a partial loss of the Power System, and that there has been substantial Load loss that has to be restored by some means or other;
“Participant”	has the meaning assigned to that term in the Market Rules;
“PAX”	means private area exchange;
“Planned Outage”	means Unless otherwise agreed between all relevant Control Centres, Planned Outages shall mean Outages, which are scheduled as part of the Outage scheduling plan and confirmed two weeks in advance. An Outage of Generating plant or part of the System other than a Forced Outage;
“Plant”	means fixed and movable equipment used in the generation and/or transmission and/or distribution of electricity other than Apparatus. For the avoidance of doubt, equipment may be considered to be Plant even though it contains LV conductors that provide electrical power for that Plant item.
“PLC”	means power line carrier;
“PME”	means protective multiple earthing;
“Point of Common Coupling (PCC)”	means that point in the Power System that represents the first shared equipment between two or more Users;
“Power Station”	has the meaning assigned to that term in the Market Rules;
“Power System Stabiliser”	means Device that injects a supplementary signal into the AVR (Automatic Voltage Regulator) in order to improve Power System damping;
“Power System”	means a network of Power Stations, Load Facilities, Transmission Systems and Distribution Systems, including the associated equipment electrically or mechanically connected;
“Pre-dispatch Day”	has the meaning assigned to that term in the Market Rules;
“Protection scheme”	means the provisions for detecting abnormal conditions in the Power System and initiating fault clearance or actuating signals or indications;

“Pre-Transitional Stage”	is the period until the Minister has approved the Market Rules and all the provisions of the Rules applicable for the Transitional Stage have become effective;
“Purchaser”	has the meaning assigned to that term in the Market Rules;
“Quantity Nomination”	has the meaning assigned to that term in the Market Rules;
“Quality of Supply”	means the quality of electrical power as measured at Connection Points. Typical parameters of power quality are the harmonic content; flicker and voltage fluctuations;
“Quick Reserve”	means Interruptible Load or capacity readily available , which can be started and Synchronized within 30 minutes to meet the system Demand. This includes hydro plant, gas turbines and pumped storage;
“Reactive Power”	means the product of voltage and current and the sine of the phase angle between them measured in units of volt-amperes reactive and standard multiples thereof; i.e. 100 VAR = 1KVAR 1000VAR = 1MVAR
Registered Capacity	For a Generating Unit other than a CCGT Module, the normal full load capacity (MW) of the Generating Unit as declared by the Generator, less the MW consumed by the Generating Unit’s unit transformer when producing at full load. For a CCGT Module, the normal full load capacity (MW) of a CCGT Module as declared by the Generator, being the Active Power declared deliverable by the CCGT Module at the Grid or Interconnected Entry Point to a network.
“Registered Information”	has the meaning assigned to that term in the Market Rules;
“Regulatory Long Term Transmission Plan”	Means the plan developed by the System Operator and approved by NERC which specifies the additions or refurbishments to be developed in the Transmission System in a predefined period in the future
“Reliability”	means in respect of the System Operator Controlled

		Grid, the ability of the System Operator Controlled Grid to operate and deliver Energy within Applicable Reliability Criteria in an adequate and secure manner;
“Reliability Agreement”	Must-run	has the meaning assigned to that term in the Market Rules;
“Reliability Must-run Unit”		has the meaning assigned to that term in the Market Rules;
“Responsible Manager”		means the person representing the Participant and shall be responsible for dealing with issues relating to this Code;
“RTU”		means remote terminal unit;
“Rules”		means the electricity market rules as defined in the Act, as amended from time to time, and approved by the Commission;
“SCADA”		means Supervisory Control and Data Acquisition;
“Secondary Regulation”		means the requirements for a Generating Unit to have its generated outputs adjusted frequently so that any Power System Frequency variations can be corrected;
“Slow Reserve”		means available capacity ready for Synchronisation to the Transmission System within 24 hours. The purpose of Slow Reserve is to replace any Generating Units on Unplanned Outages or to meet forecast Demand;
“SNCC”		means the Supplementary National Control Centre of the Nigerian ESI;
“Spinning Reserve”		means the unused capacity of Synchronised Generating Units, which can be delivered without manual intervention;
“Supervisory Control and Data Acquisition (SCADA)”		means a system of remote control and telemetry used to monitor and control the Transmission System;
“Switched Voice Circuit”		means a voice line between different Users which are established via the communication network through a process of exchanging various switching actions before the voice connection is established between the Users;
“Synchronise”		means the process of connecting two Energy supplies together in parallel or the selection of the appropriate time for switching a synchronous Generating Unit

	onto energised busbars or into parallel with another normally running synchronous Generation Unit and like terms shall be construed accordingly;
System	User(s) or TSP apparatus, equipment which can be stand alone or connected to other equipment, apparatus, employed in activities involving production, supply and consumption of electricity.
“System Disturbance”	means any disturbance that results in localised or widespread loss of load or resulting in one or more of the following phenomena: system instability, cascading Outages, formation of islands, or undesirable voltage or frequency;
“System Emergency Condition”	means the condition that the Power System is in. This is related to a shortage of generation and the Power System Frequency is dropping to below predefined emergency limits;
“System Marginal Price”	has the meaning assigned to that term in the Market Rules;
“System Minutes”	means the sum of Energy (MW Minutes) lost, divided by the peak Demand (MW) in the Power System;
“System Operator”	means the holder of a System Operator License
“System Operator Controlled Grid”	has the meaning assigned to that term in the Market Rules;
“System Stability”	means the dynamic behaviour of the Power System following a disturbance;
“System Tests”	means those tests which involve simulating conditions and recording them or the controlled application of irregular, unusual or extreme conditions on the Power System or any part of it and recording them, but not including routine testing, commissioning or re-commissioning tests;
“Total Shutdown”	means the complete seizure of the Power System to function;
“Transitional Stage”	has the meaning assigned to that term in the Market Rules;

“TCN”		means the Transmission Company of Nigeria;
“System Operator Controlled Grid”		has the meaning assigned to that term in the Market Rules;
“Transmission Constraint”		means a limit imposed on power transfer across any part of the Transmission System due to thermal overload, voltage or stability considerations;
“Transmission Loss Factor”		has the meaning assigned to that term in the Market Rules;
“Transmission Criteria”	Planning	means a set of criteria to be used to plan and develop the Transmission System;
“Transmission System”		means the system or network of electric lines comprising wholly or mainly high voltage lines and electric plant and which is used for Transmission of Energy from a Power Station to a substation, from one Power Station to another, from one substation to another or to or from any Interconnector or to final consumers, and includes any structures and equipment’s for that purpose;
“Transmitter”		has the meaning assigned to that term in the Market Rules;
“Uninstructed Quantities”	Imbalance	has the meaning assigned to that term in the Market Rules;
“Unplanned Outage”		means unless otherwise agreed between all relevant Control Centres, Unplanned Outages shall mean Outages which are not scheduled with the advance notice;
“Uplift”		has the meaning assigned to that term in the Market Rules;
“Usage Charges”		has the meaning assigned to that term in the Market Rules;
“Users”		A person or party using Transmission network / System as agreed and permitted by the TSP
“Voltage Control”		means The retention of the Voltage on the System within acceptable limits;
“Voltage Dip”		means a sudden reduction of the voltage to a value between 90% and 100% of the nominal voltage

	followed by a voltage recovery after a short period of time;
“Voltage Fluctuations”	means a series of rapid voltage changes, which may be regular or irregular;
“Voltage Reduction”	means the method to temporarily control Demand by reduction of System voltage;
“Voltage Support”	means injection or withdrawal of Reactive Power by means of changing the excitation of Generating Units or operation of reactive compensation devices to maintain voltages across the Power System within a specified range;
“Voltage Unbalance”	means a condition in a three-phase network in which the root-mean-square value of the phase voltages or the phase angles between consecutive phases is not equal;
“VT”	means voltage transformer; and

Appendix 2: Conditions Precedent

The Conditions Precedent are:

- (A) enactment into law of the Electric Power Sector Reform Act;
- (B) the incorporation of Transysco as one of the successor company to Power Holding Company of Nigeria.

Appendix 3: Reliability Concepts and Definitions

3.1 INTRODUCTION

The Nigerian Power System consists of those Generation and Transmission facilities, which are controlled by the Transysco and which function as part of an integrated and coordinated power supply network.

In order to maintain reliable operation of the Transmission System, it is necessary that all systems observe and subscribe to certain minimum planning criteria. The criteria and principles provided in this Appendix serves a guideline to develop criteria and methodologies applicable to the Transysco and related interconnections and customers.

The Appendix consists of three sections of which:

Section 2 provides guidelines to transmission contingency criteria based of NERC standards,

Section 3 provides guidelines to the measuring of Reliability indices in order to produce annual performance figures, and

Section 4 provides guidelines with regard to the measurement of the value of network infrastructure.

This Appendix thus provides guidelines that can be used to direct the Transysco planning and operational criteria in future. It does not provide the procedures and measures required to ensure that the criteria is followed. Neither does the Appendix direct responsibility to any of the Transysco members. These issues will need to be developed and resolved before criteria of this nature can effectively be implemented.

3.2 TRANSMISSION RELIABILITY CRITERIA

In general an interconnection philosophy is to minimize loss of load by remaining interconnected. Interconnected System planning will include steady state and dynamic simulated testing to represent specific occurrences for each type of contingency specified below or listed in Table 2 of this Planning Standard. The contingency tests will be performed for reasonable variations of load level, Dispatch Schedules, planned Transmission line maintenance outages, and anticipated power transfers. At a minimum, this should include projected loads for the upcoming dry and wet seasons and a ten-year planning horizon. The Transmission providers involved should plan to resolve any unacceptable test results through the provision of Transmission Facilities, the alteration of operating procedures, or other means as appropriate.

While the requirements listed in Table 2 address most planning concerns, tests will also be conducted to ensure that the planned system conforms to the following additional requirements:

The contingency loss of a double-circuit Transmission line that exceeds 0.5 kilometres in length (either without a fault or subsequent to a normally-cleared non-three-phase fault) with all other facilities normal should not cause a) cascading or uncontrolled outages, b) instability of Generating Units at multiple plant locations, or c) interruption of service to firm Demand or

Generation other than that isolated by the double-circuit loss, following the execution of all automatic operating actions such as relaying and special protection systems. Furthermore, the loss should result in no damage to or failure of equipment and, following the execution of specific non-automatic predefined operator-directed actions such as re-dispatch, curtailment of interruptible load, or curtailment of unplanned transfers, should not result in applicable voltage or thermal ratings being exceeded.

With any single Generating Unit unavailable, and with any other generation pre-emptively re-dispatched, the contingency loss of a single transmission element (either without a fault or subsequent to a normally-cleared non-three-phase fault) with all other facilities normal should not cause a) cascading or uncontrolled outages, b) instability of Generating Units at multiple plant locations, or c) interruption of service to firm Demand or generation other than that isolated by the transmission element, following the execution of all automatic operating actions such as relaying and special protection systems. Furthermore, the loss should result in no damage to or failure of equipment and, following the execution of specific non-automatic predefined operator-directed actions such as re-dispatch, curtailment of interruptible load, or curtailment of unplanned transfers, should not result in applicable voltage or thermal ratings being exceeded.

3.2.1 Report and Testing

Annual preparation of adequacy indices of the Transysco power system will be required. This should be read in conjunction with the long-term planning reports for infrastructure additions with possible quantification of the worth of these network additions as outlined in Section 4. These working papers to report the results of system tests future planning reports will provide the basis for statements concerning the adequacy of the planned Nigeria Transysco System.

Table A2. Transmission Systems Standards — Normal and Contingency Conditions

Category	Contingencies		System Limits or Impacts					
	Initiating Event(s) and Contingency Component(s)		Components Out of Service	Thermal Limits	Voltage Limits	System Stable	Loss of Demand or Curtailed Firm Transfers	Cascading ^c Outages
A – No Contingencies	All Facilities in Service		None	Normal	Normal	Yes	No	No
B – Event resulting in the loss of a single component.	Single Line Ground (SLG) or 3-Phase (3Ø) Fault, with Normal Clearing: 1. Generator 2. Transmission Circuit 3. Transformer Loss of a Component without a Fault.		Single Single Single Single	Applicable Rating ^a (A/R) A/R A/R A/R	Applicable Rating ^a (A/R) A/R A/R A/R	Yes Yes Yes Yes	No ^b No ^b No ^b No ^b	No No No No
C – Event(s) resulting in the loss of two or more (multiple) components.	SLG Fault, with Normal Clearing: 1. Bus Section 2. Breaker (failure or internal fault)		Multiple Multiple	A/R A/R	A/R A/R	Yes Yes	Planned ^d Planned ^d	No No
	SLG or 3Ø Fault, with Normal Clearing, Manual System Adjustments, followed by another SLG or 3Ø Fault, with Normal Clearing: 3. Category B (B1, B2, B3) contingency, manual system adjustments, followed by another Category B (B1, B2, B3) contingency		Multiple	A/R	A/R	Yes	Planned ^d	No
	Fault (non 3Ø), with Normal Clearing: 4. Double Circuit Towerline		Multiple	A/R	A/R	Yes	Planned ^d	No
	SLG Fault, with Delayed Clearing: 5. Generator 6. Transmission Circuit 8. Transformer 9. Bus Section		Multiple Multiple	A/R A/R	A/R A/R	Yes Yes	Planned ^d Planned ^d	No No
D ^c – Extreme event resulting in two or more (multiple) components removed or cascading out of	3Ø Fault, with Delayed Clearing (stuck breaker or protection system failure): 1. Generator 2. Transmission Circuit 3. Transformer 4. Bus Section 3Ø Fault, with Normal Clearing: 5. Breaker (failure or internal fault) Other:		Evaluate for risks and consequences. ▪ May involve substantial loss of customer demand and generation in a widespread area or areas.					

<p>service</p>	<ol style="list-style-type: none"> 6. Loss of towerline with three or more circuits 7. All transmission lines on a common right-of way 8. Loss of a substation (one voltage level plus transformers) 9. Loss of a switching station (one voltage level plus transformers) 10. Loss of all generating units at a station 11. Loss of a large load or major load center 12. Failure of a fully redundant special protection system (or remedial action scheme) to operate when required 13. Operation, partial operation, or misoperation of a fully redundant special protection system (or remedial action scheme) for an event or condition for which it was not intended to operate 14. Impact of severe power swings or oscillations from disturbances in another Regional Council. 	<ul style="list-style-type: none"> ▪ Portions or all of the interconnected systems may or may not achieve a new, stable operating point. ▪ Evaluation of these events may require joint studies with neighboring systems. ▪ Document measures or procedures to mitigate the extent and effects of such events. ▪ Mitigation or elimination of the risks and consequences of these events shall be at the discretion of the entities responsible for the reliability of the interconnected Transmission Systems.
----------------	---	---

Footnotes to Table A2.

- a) Applicable rating (A/R) refers to the applicable normal and emergency Facility thermal rating or system voltage limit as determined and consistently applied by the system or Facility owner.
- b) Planned or controlled interruption of generators or electric supply to radial customers or some local network Customers, connected to or supplied by the faulted component or by the affected area, may occur in certain areas without impacting the overall security of the interconnected transmission systems. To prepare for the next contingency, system adjustments are permitted, including curtailments of contracted firm (non-recallable reserved) electric power transfers.
- c) Cascading is the uncontrolled successive loss of system elements triggered by an incident at any location. Cascading results in widespread service interruption which cannot be restrained from sequentially spreading beyond an area predetermined by appropriate studies.
- d) Depending on system design and expected system impacts, the controlled interruption of electric supply to customers (Load Shedding), the planned removal from service of certain Generators, or the curtailment of contracted firm (non-recallable reserved) electric power transfers may be necessary to maintain the overall security of the Interconnected Transmission Systems.

- e) A number of extreme contingencies that are listed under Category D and judged to be critical by the transmission planning entity(ies) will be selected for evaluation. It is not expected that all possible Facility Outages under each listed contingency of Category D will be evaluated.

3.3 RELIABILITY MEASURES

3.3.1 Reliability indices

The fundamental attributes for probabilistic Reliability measures to be considered to evaluate risk of probable extreme events as discussed in Table 2 include:

- The Frequency of events (e.g. frequency of circuit overload – 0.72 events/year),
- Duration of events (e.g. duration of circuit overload – 2.5 hours/year), and
- Severity of events (how does event impact on load curtailment)

From these attributes other indices to quantify network performance can be calculated. To enable the definition of applicable indices, which may apply to the Nigeria Transysco, a number of concepts and definitions related to network, configuration and aspects influencing network performance are discussed below. These concepts and definitions are taken from Reference [1] ¹.

3.3.2 Concepts and Definitions

Bulk system Reliability performance is normally measured in terms of the amount of Unreliability created by events in the bulk system, such as discussed in Table 2. Unreliability denotes the inability to provide the required supply to all customers connected to the bulk system. This involves loss of load to the bulk system, or may be indirectly through the Distribution System.

Furthermore a bulk system unreliability event can be defined as an event in the bulk system representing the inability to supply load to one or more customers. This inability may be a consequence of manual actions or of automatic operations of protective devices.

3.3.2.1 Manual Actions to Avoid Unreliability

These are defined as actions to:

- Adjust voltage and power flow through transformer tap changers,
- Re-dispatch generation,
- Reduce sales/ increase purchases from interconnections, and
- Manual actions such as switching operations.

Unreliability by Reducing Load.

These are defined as actions such as:

- Shed interruptible loads,
- Reduce system-wide voltage,
- Appeal to public or key customers to reduce demand, and
- Institute rotational Load Shedding.

3.3.2.2 Automatic Operations Signifying Unreliability

¹ C.C. Fong, R. Billinton, R.O. Gunderson, P.M. O'Neill, J. Raksany, A.W. Schneider, Jr, B. Silverstein, "Bulk System Reliability – Measurement and Indices". IEEE Trans. On Power Systems, Vol.4, No.32, August 1989, pp. 829-835

Automatic, intentional load shedding by devices designed to prevent or minimize a System Disturbance.

Interruption of supply due to bulk system equipment Outages causing loss of continuity.

System Disturbance that is widespread load loss involving one or more of the following phenomena: system instability, cascading Outages, formation of islands, or undesirable Voltage or Frequency.

The manual actions to avoid unreliability listed above are usually taken to avoid violation of operating security limits in anticipation of further Outages that may cause Unreliability. The manual actions to confine Unreliability, on the other hand, are usually taken when a condition such as capacity or energy shortfall has already occurred, in order to minimize its consequences.

Summarizing, the proposed measurement system concentrates on the following Unreliability events:

- Interruption of supply due to loss of continuity,
- System Disturbance, and
- Automatic and rotational Load Shedding.

3.3.2.3 Monitoring Points

With the above in mind, two types of monitoring points are defined. They are illustrated conceptually in Figure 1: and are defined as follows:

Radial Delivery Point: A radial delivery point is:

A Low Voltage bus of a Transformer. The bus radially supplies a Distribution System, or

A point in the bulk system, which is an interface between Utility-owned Facilities and Customer-owned facilities. The point radially supplies the Customer.

Significant point: This is a bus or a point within the bulk system, where the utility deems it important to monitor the reliability of service. This type of monitoring point recognizes that there may be special purpose monitoring points that are different from radial or meshed delivery points.

This distinction between radial and meshed delivery points is that interruption of radial delivery points result in load loss, whereas interruption of meshed delivery points does not always result in load loss but could result in inadequate service conditions.

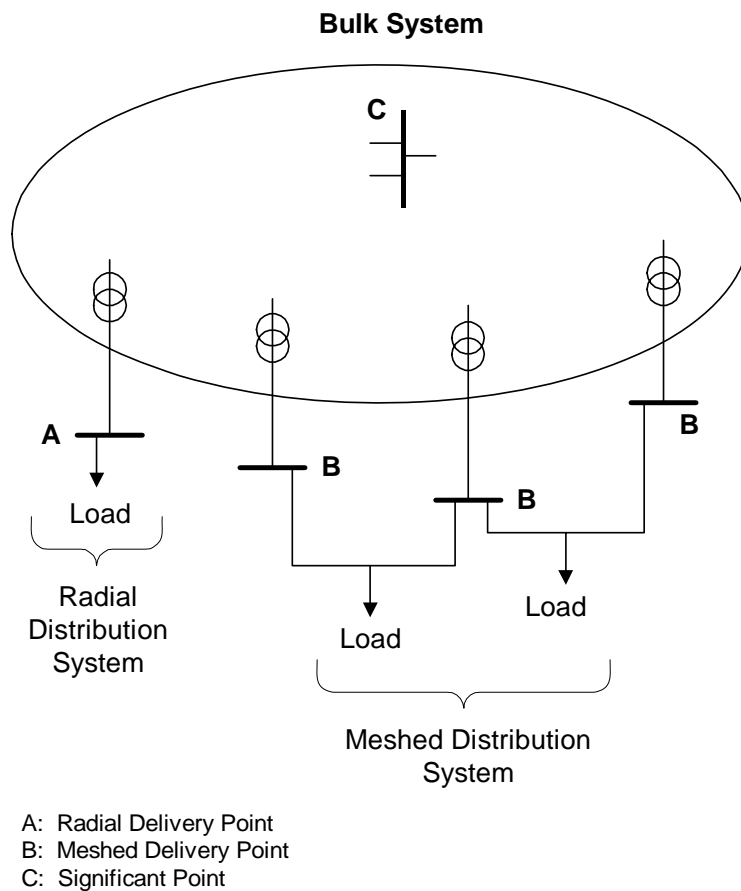

Figure 1: Measurement Points

Figure 2: further illustrates the two types of delivery points. For example, Point A radially supplies a customer owned system directly connected to the bulk system. It is, therefore, a radial delivery point. Point B is a low voltage bus radially supplying a Distribution System, and is also a radial delivery point. Point C is a meshed delivery point. It supplies a meshed Distribution System which is also supplied from another meshed delivery point – Point D. Points E and F are meshed delivery points supplying a meshed system owned by the customer.

Although not common, it is possible that a low voltage bus supplies both a radial and a meshed Distribution System. Such a bus may be classified for convenience as a radial delivery point.

An example of a significant point is the bulk system supply to a power station. The station may rely on bulk system supply in case of a unit shutdown. An interruption of supply (whether the supply is needed by the station or not) is sometimes referred to as “loss of off-site power”. The bus where measurement takes place may be on the Low Voltage side of the station service Transformer associated with the Unit. Another example is an

important interconnection with a neighbouring Utility or non-Utility System. A third example could be the bulk system's supply to its own system control centre.

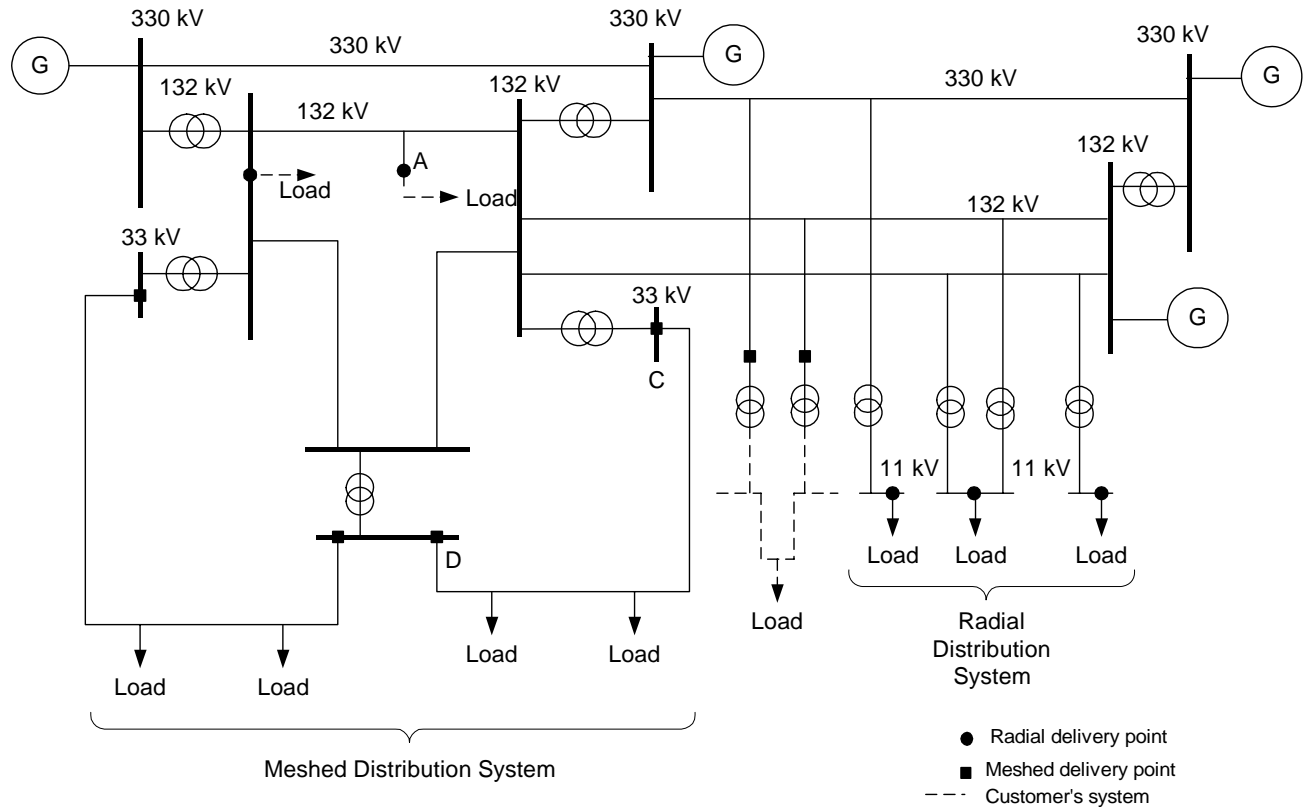

Figure 2: NEPA Bulk System

3.3.3 Basic Indices

Several fundamental indices are proposed. These can be expanded based on the Transysco needs. All of these indices can be calculated for a defined recording period. The length of the period should be measured in years to facilitate comparison.

Delivery Point Interruption Indices

(a) Individual Delivery Point Indices: For each delivery point (radial or meshed):

$$\text{Interruption Frequency} = \frac{\text{No. of Interruptions}}{\text{Period (Years)}}$$

$$\text{Annual Interruption Duration} = \frac{\text{Sum of Interruption Durations}}{\text{Period (Years)}}$$

$$\text{Average Duration per Interruption} = \frac{\text{Sum of Interruption Durations}}{\text{No. of Interruptions}}$$

$$\text{Annual Load Interrupted} = \frac{\text{Sum of MW Interrupted}}{\text{Period (Years)}}$$

$$\text{Annual Unsupplied Energy} = \frac{\text{Sum of Unsupplied Energy}}{\text{Period (Years)}}$$

$$\text{Delivery Point Interruption Severity} = \sum_i \frac{\text{Total Unsupplied Energy (MW minutes) in Year } i}{\text{Delivery Point Peak Load (MW) in Year } i}$$

(b) System-Wide Delivery Point Indices: For the bulk system and for each type of delivery point (radial or meshed):

$$\text{System Average Interruption Frequency} = \frac{\text{No. of Interruptions}}{\text{Delivery Point– years}}$$

$$\text{System Average Interruption Duration} = \frac{\text{Sum of Interruption Durations}}{\text{Delivery Point– Years}}$$

$$\text{System Average Restoration Duration} = \frac{\text{Sum of Interruption Durations}}{\text{Number of Interruptions}}$$

$$\text{System Average Load Interrupted} = \frac{\text{Sum of MW Interrupted}}{\text{Delivery Point– Years}}$$

$$\text{System Average Unsupplied Energy} = \frac{\text{Sum of Unsupplied Energy}}{\text{Delivery Point– Years}}$$

$$\text{System Interruption Severity} = \sum_i \frac{\text{Total Unsupplied Energy (MW Minutes) in Year } i}{\text{System Peak Load (MW) in Year } i}$$

Indices for Interruption of a Significant Point

For each significant point

$$\text{Interruption Frequency} = \frac{\text{No. of Interruptions}}{\text{Period (Years)}}$$

$$\text{Annual Interruption Duration} = \frac{\text{Sum of Interruption Durations}}{\text{Period (Years)}}$$

The monitoring of significant points is very specific to the needs of individual operations. “System-wide” average indices are not suggested here but may be considered, for groups of significant points.

Automatic and Rotational Load Shedding Indices

For each type of load shedding:

$$\text{Frequency} = \frac{\text{No. of Events}}{\text{Periods (Years)}}$$

$$\text{Load Shedding Severity} = \sum_i \frac{\text{Total Unsup plied Energy (MW Minutes) in Year } i}{\text{System Peak (MW) in Year } i}$$

These indices may also be calculated for a specific automatic scheme, to indicate its impact on bulk system reliability. The Load Shedding Severity Index is expressed in System Minutes.

System Disturbance Indices

For an individual System Disturbance:

$$\text{System Disturbance Severity} = \frac{\text{Unsup plied Energy (MW Minutes)}}{\text{Annual System Peak (MW)}}$$

This index is expressed in System Minutes. It is again fundamentally the same as the Bulk Power Energy Curtailment Index in, but is applied to an individual System Disturbance in this case.

3.4 VALUE OF NETWORK PERFORMANCE

Broadly speaking, the cost of an interruption from a customer's perspective is related to the nature of the degree to which the activities interrupted are dependent on electricity. This dependency can be translated to a Customer Damage Function (CDF) that provides the severity of an interruption in relation to the duration of the interruption for a specific customer or group of customers. In turn, this dependency is a function of both customer and interruption characteristics. Customer characteristics include:

- Type of customer;
- Nature of the customer's activities;
- Size of operation, and other demographic data;
- Demand, and energy requirements; and
- Energy dependency as a function of time of day, etc.
- Interruption characteristics include:
 - Duration;
 - Frequency;
 - Time of occurrence of interruptions;
 - Whether an interruption is complete or partial;
 - If advance warning or duration information is supplied by the utility; and
 - Whether the area affected by the outage is localized or widespread.

3.4.1 Application of Customer Interruption Cost

The broadest application of a Customer Damage Function is its use to relate the composite customer losses to the socio-economic worth of electric service Reliability for an entire Utility Service Area ². The cost estimates can be obtained by multiplying the Expected Unserved Energy to customers due to interruptions by a suitable factor, designated as the Interrupted Energy Assessment Rate (IEAR) expressed in \$/kWh.

² Li Wenyuan, R. Billinton, "A Minimum Cost Assessment Method for Composite Generation and Transmission System Expansion Planning", IEEE Trans. On Power Systems, Vol.8, No.2, May 1993, pp. 628-635

3.4.2 Regulation of Interruption Cost

A number of countries are introducing voluntary and regulator imposed schemes that require payments to be made to customers interrupted due to poor performance of the supply network. Typically, payments are only made if supply is not restored within a pre-determined time after the customer advises that their supply is off. Payments are often not required for events outside the control of companies such as extreme weather disruptions.

Australia

The ownership structure in Australia varies from state to state as the industry is in a state of transition. Independent regulatory bodies are established in most states to facilitate electricity markets. There is a single commercial regulatory body in each state with responsibility for setting prices for retail energy and prices for Transmission and Distribution Access.

Regulations in Australia specify minimum standards of service for distribution business together with the prescribed compensation payments that suppliers have to pay to their customers. There is a range of poor performance payments, one of which is failing to provide to a customer at least two business days' notice of any planned interruption (not less than AU\$20).

Currently there are neither mandatory nor voluntary schemes in place in Australia that require payments to be made to customers for power supply interruptions. Written and detailed compensation claims are processed on a case-by-case basis. This practice is likely to be simplified shortly. For example, one supplier has proposed to credit AU\$40 (about US\$26) to the accounts of residential customers if the supply is not restored within 4 hours of a fault being reported.

Great Britain

All Public Electricity Suppliers (PESs) in Great Britain are required to report annually to the Director General on their performance against certain Standards which are set under Sections 39 and 40 of the Electricity Act 1989. These Standards cover the provision by PESs of services to customers in the distribution, supply and metering of electricity. They are set by the Director General after wide consultation and have been continuously updated since first being introduced in July 1991. The achieved performance is annually reported.

To ensure that inconvenience to customers is kept to a minimum, the Standard requires companies to restore the supply within 24 hours of the company becoming aware of a fault on the Distribution System. If the company fails to meet this Standard the customer is entitled to claim a payment.

Norway

According to Norwegian legislation, network operation is (still) a monopoly while there is an open market, subject to competition, for buying and selling electric Energy. Norway does not require separate ownership of Network Companies, Power Producers and Energy Retailers.

In order to increase the cost-effectiveness of the transmission and distribution monopoly, the Utilities are instructed to reduce their total costs by 1.5 – 4.5 % per year throughout the year 2001. This may lead to postponed investments, reduced maintenance and reduction of staff and also result in reduced supply reliability. Since supply reliability as well as cost-effectiveness are both important objectives, the regulator (NVE) has announced the

introduction of a disruption payment arrangement from 2001 intended to provide two aspects:

**Supply reliability regulation; and
Financial compensation for energy not supplied (EUE).**

The first aspect is directed towards the Utilities and intended to counteract a possible tendency to obtain cost-effectiveness on the expense of supply Reliability. The objective is to give the network companies incentives to operate and maintain the network in a socio-economic optimal way.

The second aspect is directed towards the customers to give compensation to those customers suffering power interruptions. The Norwegian Energy Act put into force in 1991 stated the principle of having a Reliability level based on socio-economic optimization. The meaning is that worth of Reliability to society, expressed by interruption costs, is an important aspect, which should have a decisive influence on the level of Reliability offered to the customers. The consequence is that networks are planned and operated such that customers with high interruption costs will have a high degree of Reliability while those with low interruption costs will have less reliable supply. Thus, compensation for energy not supplied is a mechanism to control this aspect given that compensation is based on interruption cost figures.

3.5 CONCLUSION

This Appendix serves as a guideline for the Transysco to develop applicable Reliability measures and methodologies to maintain reliable operation of the Transmission System

The Appendix provided fundamental concepts relating to:

- Transmission contingency criteria based of NERC standards,
- The measuring of Reliability indices in order to produce annual performance figures, and
- Guidelines with regard to the measurement of the value of network infrastructure.

APPENDIX 4A – RECORD OF NETWORK SAFETY PRECAUTIONS

[TRANSYSO] [_____ CONTROL CENTRE/SITE]

RECORD OF NETWORK SAFETY PRECAUTIONS REQUEST (RNSP-R)
(Requesting Safety Co-ordinator's Record)

RNSP NUMBER
 PART 1

1.1 High Voltage Equipment Identification

Safety Precautions have been established by the implementing **Safety Co-ordinator** (or by another **User** on that **User's equipment** connected to the implementing **Safety Co-ordinator's equipment**) to achieve (in so far as it is possible from that side of the **Connection Point**) **Safety From** the equipment on the following **High Voltage** equipment on the **Requesting Safety Co-ordinator's equipment**:

[State identity - name(s) and, where applicable, identification of the **HV** circuit(s) up to the **Connection Point**]:

Further **Safety precautions** required on the requesting **Safety Co-ordinator's equipment** as notified by the implementing **Safety Co-ordinator**.

1.2 SAFETY PRECAUTIONS ESTABLISHED

(a) ISOLATION

[State the **Location(s)** at which **Isolation** has been established (whether on the implementing **Safety Co-ordinator's equipment** or on the equipment of another **User** connected to the implementing **Safety Co-ordinator's equipment**). For each **Location**, identify each point of **Isolation**. For each point of **Isolation**, state the means by which the **Isolation** has been achieved, and whether, immobilised and **Locked**, **Caution Notice** affixed, other safety procedures applied, as appropriate.]

(b) EARTHING

[State the **Location(s)** at which **Earthing** has been established (whether on the implementing **Safety Co-ordinator's equipment** or on the **System** of another **User** connected to the **implementing Safety Co-ordinator's System**). For each **Location**, identify each point of **Earthing**. For each point of **Earthing**, state the means by which **Earthing** has been achieved, and whether, immobilised and **Locked**, other safety procedures applied, as appropriate].

1.3 ISSUE

I have received confirmation from _____ (name of **Implementing Safety Coordinator**) at _____ (location) that the **Safety Precautions** identified in paragraph 1.2 have been established and that instructions will not be issued at his location for their removal until this **RNSP** is cancelled.

Signed(**Requesting Safety Co-ordinator**)
 at(time) on (Date)

PART 2

2.1 CANCELLATION

I have confirmed to _____ (name of the implementing **Safety Co-ordinator**) at _____ (location) that the **Safety Precautions** set out in paragraph 1.2 are no longer required and accordingly the **RNSP** is cancelled.

Signed(**Requesting Safety Co-ordinator**)
 at(time) on (Date)

APPENDIX 4B

[TRANSYSO] [_____ CONTROL CENTRE/SITE]
RECORD OF NETWORK SAFETY PRECAUTIONS IMPLEMENTATION (RNSP-I)
 (Implementing Safety Co-ordinator's Record)

PART 1 RNSP NUMBER

1.1 High Voltage Equipment IDENTIFICATION

Safety Precautions have been established by the implementing **Safety Co-ordinator** (or by another **User** on that **User's equipment** connected to the implementing **Safety Co-ordinator's equipment**) to achieve (in so far as it is possible from that side of the **Connection Point**) **Safety From The System** on the following **High Voltage equipment** on the **Requesting Safety Co-ordinator's equipment**.

[State identity - name(s) and, where applicable, identification of the **High Voltage** circuit(s) up to the **Connection Point**]:

Recording of notification given to the **Requesting Safety Co-ordinator** concerning further **Safety Precautions** required on the **Requesting Safety Co-ordinator's equipment**.

1.2 SAFETY PRECAUTIONS ESTABLISHED

(a) **ISOLATION**

[State the **Location(s)** at which **Isolation** has been established (whether on the implementing **Safety Co-ordinator's equipment** or on the **System** of another **User** connected to the implementing **Safety Co-ordinator's equipment**). For each **Location**, identify each point of **Isolation**. For each point of **Isolation**, state the means by which the **Isolation** has been achieved, and whether, immobilised and **Locked**, **Caution Notice** affixed, other safety procedures applied, as appropriate.]

(b) **EARTHING**

[State the **Location(s)** at which **Earthing** has been established (whether on the implementing **Safety Co-ordinator's equipment** or on the **System** of another **User** connected to the **Implementing Safety Co-ordinator's System**). For each **Location**, identify each point of **Earthing**. For each point of **Earthing**, state the means by which **Earthing** has been achieved, and whether, immobilised and **Locked**, other safety procedures applied, as appropriate].

1.3 ISSUE

I have confirmed to _____ (name of **Requesting Safety Co-ordinator**) at _____ (location) that the **Safety Precautions** identified in paragraph 1.2 have been established and that instructions will not be issued at my location for their removal until this **RNSP** is cancelled.

Signed(Implementing Safety Co-ordinator)
 at(time) on (Date)

PART 2

2.1 CANCELLATION

I have received confirmation from _____ (name of the **Requesting Safety Co-ordinator**) at _____ (location) that the **Safety Precautions** set out in paragraph 1.2 are no longer required and accordingly the **RNSP** is cancelled.

Signed(Implementing Safety Co-ordinator)
 at(time) on (Date)

(Note: This form to be of a different colour from RNSP-R)

APPENDIX 4C – RNSP ISSUE PROCESS

RSC – Requesting Safety Co-ordinator
Person requiring Safety Precaution from another User

ISC – Implementing Safety Co-ordinator
Person who co-ordinates provision of Safety Precautions

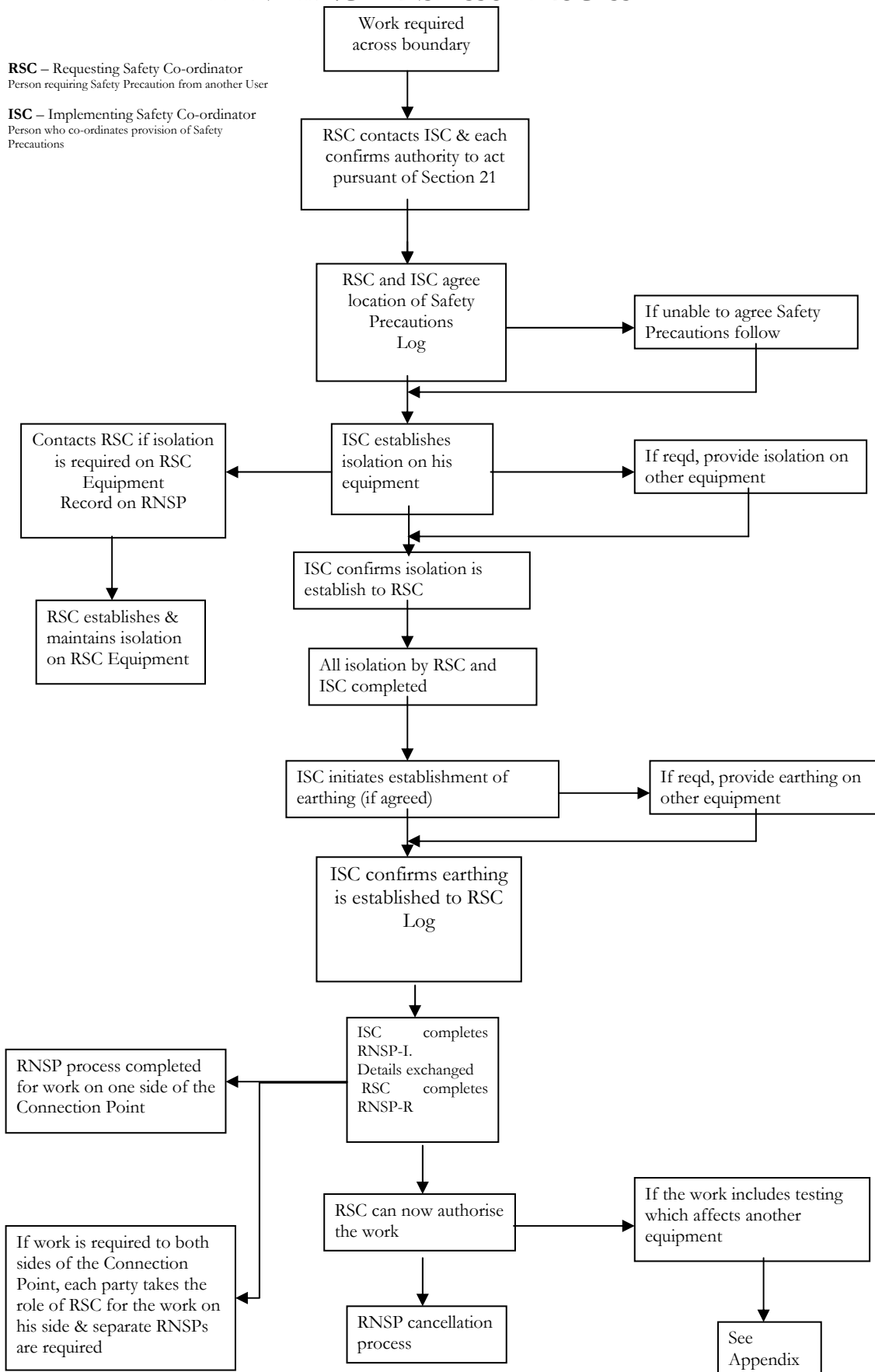

APPENDIX 4D – RNSP CANCELLATION PROCESS

RSC – Requesting Safety Co-ordinator

Person requiring Safety Precaution from another User

ISC – Implementing Safety Co-ordinator

Person who co-ordinates provision of Safety Precautions

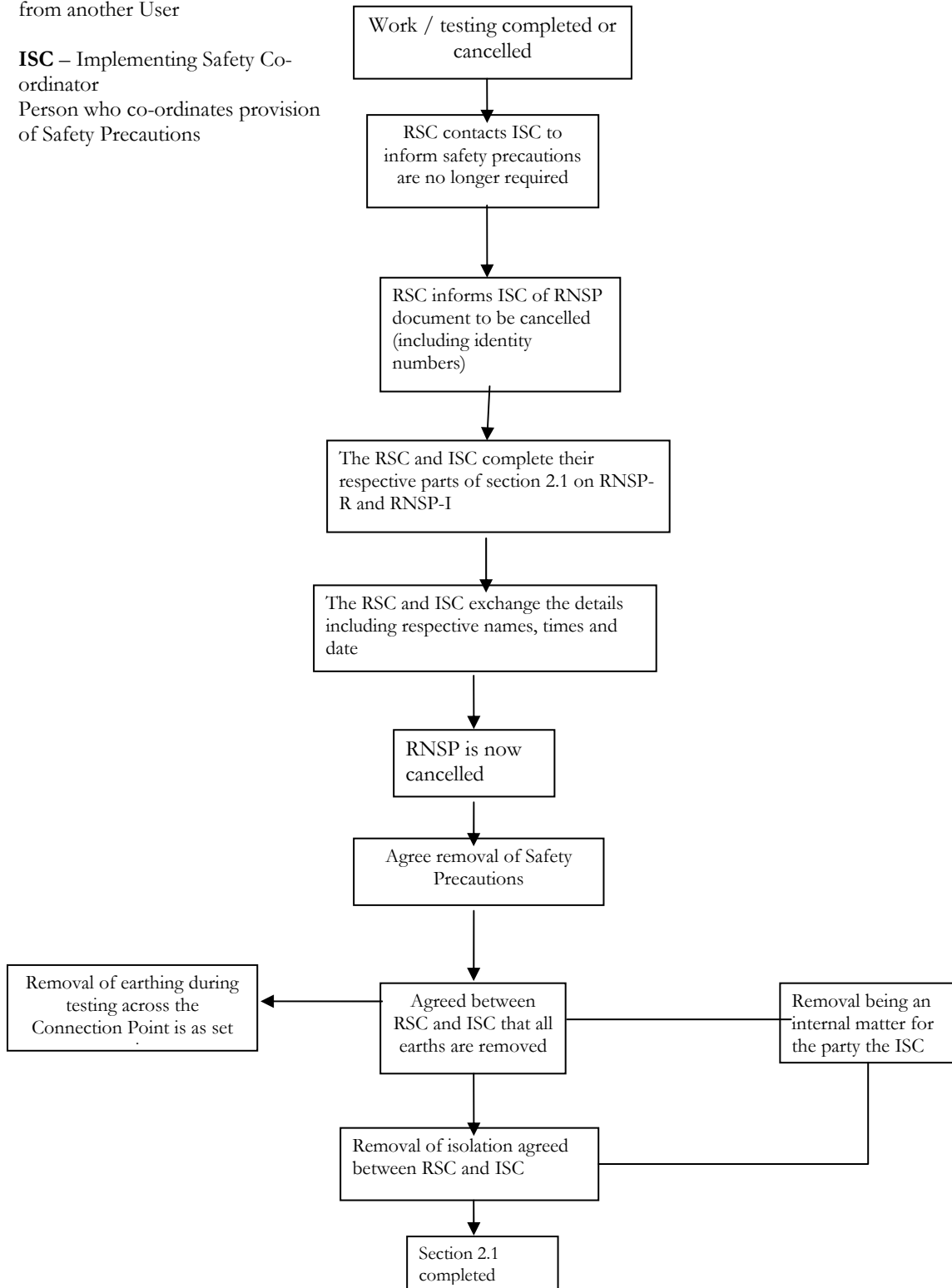

APPENDIX 4E – RNSP TESTING PROCESS

RSC – Requesting Safety Co-ordinator
Person requiring Safety Precaution from another User

ISC – Implementing Safety Co-ordinator
Person who co-ordinates provision of Safety Precautions

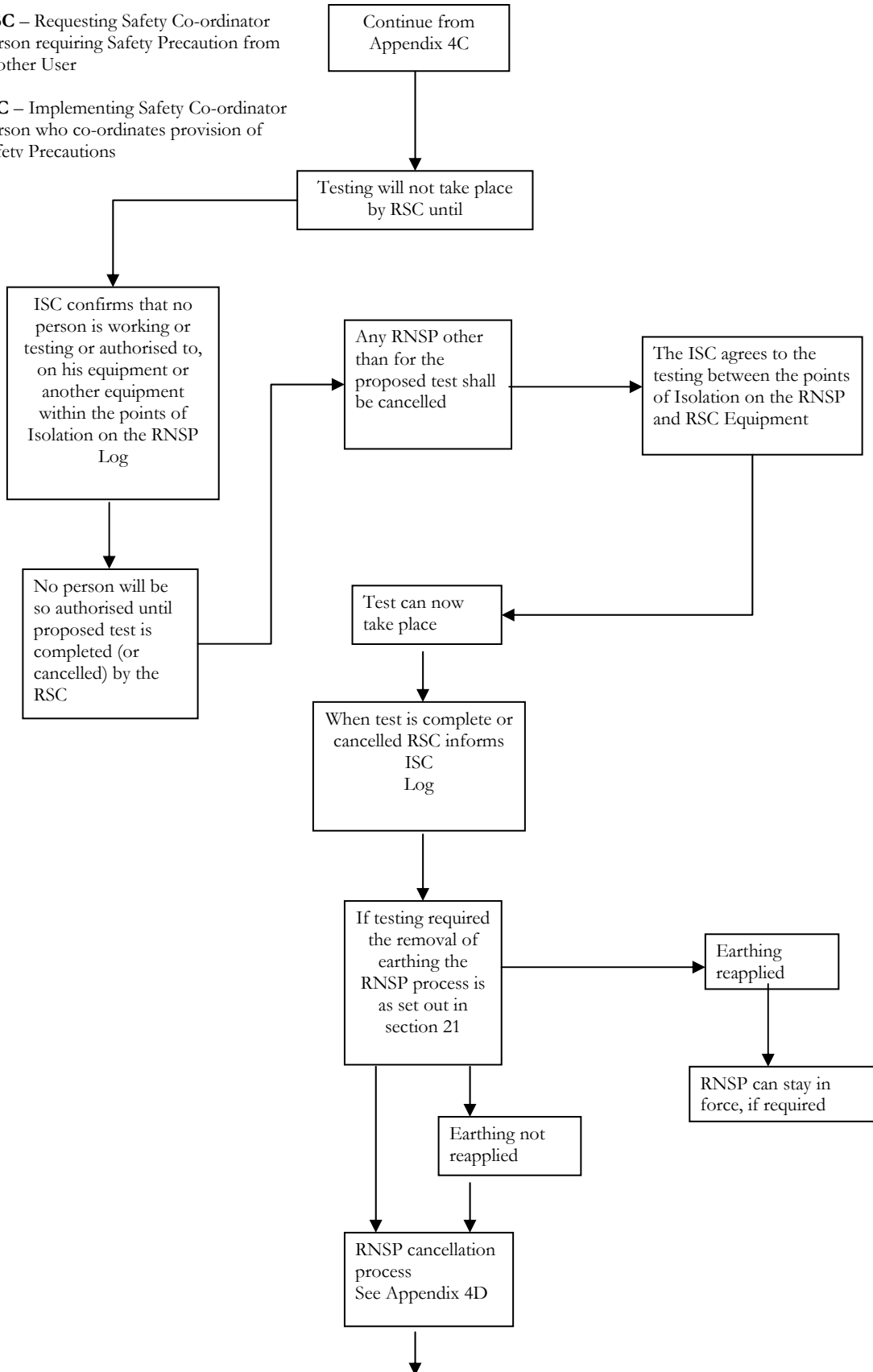

APPENDIX 5 – DATA REGISTRATION REQUIREMENTS

5.1 Introduction:

The System Planning specifies the technical and design criteria and procedures to be adopted by the Transysco for the planning and development of the Transmission System. The Users of the Transmission System shall take the Data Registration for system planning into account for planning and development of their own Equipment or Apparatus.

5.1.1 Reinforcements and extensions to the Transmission Network arise due to many reasons of which a few are mentioned below:

1. A development on a User's Equipment or Apparatus already connected to the Transmission Network as a User development.
2. Introduction of a new connection point between a User's Equipment or Apparatus and the Transmission Network.
3. The need to increase Transmission Network capacity, removal of operational constraints, maintenance of Security Standards and meeting general increases in Demand.
4. Steady state and transient stability considerations.
5. Cumulative effects of any combination of the above four.

5.1.2 The work of such reinforcement and extension to the Transmission Network may also involve work at a connecting point (entry or exit) of a Generating Station/Distribution Company to the Transmission Network.

5.1.3 The development of the Transmission Network must be planned in advance duly allowing sufficient lead time, considering the following:

1. Time required for obtaining all the necessary statutory approvals like Environmental Impact Assessment clearance, Forest clearance, Road or Railway clearance, clearance from aviation authorities, etc., and the right of way permissions wherever required,
 2. Time required for detailed engineering, design and construction work to be carried out.
- This Network Planning, therefore, enforces the time scales for exchange of information between the Transysco and the User(s). All the concerned parties, wherever appropriate, shall have due regard to the confidentiality of such information.

To enable the Transysco to discharge its responsibilities under its Transmission Licence Conditions by conducting System Studies and preparation of perspective plans for Demand, Generation and Transmission Network expansion as detailed under the Grid Code, all Users of the Transmission Network shall furnish all the data to the Transysco from time to time detailed below under Data Registration Requirement of Sections 15 and 16.

BASIC DATA REQUIREMENTS BASED ON SECTIONS 15, 16

PART-1 - GENERATION

(To be furnished by Users of Generating Unit to Transysco)

5A Standard Planning Data (Generation)

THERMAL

I. GENERAL: -

1. Site:	<ul style="list-style-type: none"> i. Furnish location map to scale showing roads, Railway lines, Transmission lines, Rivers, and reservoirs if any. ii. Fuel linkage (Natural Gas, Naptha, Oil pipeline) iii. Furnish information on means of Coal transport from mines or means of coal carriage if coal is to be brought from distance. iv. In case of other fuels, furnish details of sources of fuel and their transport. v. Water Sources (furnish information on availability of water for operation of the power Station). vi. Environmental (State whether forest, lands mining clearance areas are affected).
2. Site Map: (To scale)	Showing area required for power station coal linkage, coal yard, water pipe line, ash disposal area, colony etc.
<ul style="list-style-type: none"> 3. Approximate period of construction. 4. Guaranteed Plant Load Factor. 5. Annual Generation. 	

 II. Connection:

1. Point of connection	Furnish single line diagram of the proposed connection with the system.
2. Step up voltage for connection in kV	
III. <u>Station Capacity:</u>	
1. Total Power Station capacity (MW).	MW
2. Ancillary Services provided	
3. No. of Units and Unit size MW.	State whether development will be carried out in phases and if so, furnish details.
4. Generator Unit Data:	<ul style="list-style-type: none"> i. Steam Turbine- State Type, capacity, steam pressure, steam temperature, heat rate, efficiency etc. ii. Generator: <ul style="list-style-type: none"> a) Type b) Rating (MVA) c) Terminal Voltage (kV) d) Rated Power Factor e) Frequency Response Table f) Reactive Power capability (MVA_r) in the range 0.95 leading and 0.85 lagging. g) Short Circuit Ratio h) Direct axis transient reactance (% on MVA rating) i) Direct axis sub-transient reactance (% on MVA rating) j) Auxiliary Power requirement iii. Generator Transformer / Station Transformer <ul style="list-style-type: none"> a) Rated Capacity (MVA)

	b) Voltage Ratio (HV/LV) c) Tap change range (+% to -%) d) Percentage Impedance (Positive Sequence at Full load).
--	---

5B Hydro Electric:

1. General:

1. Site	Furnish location map to scale showing roads, railway lines, Transmission lines
2. Site Map (To scale)	Map showing proposed dam, reservoir area, water conductor system, fore bay, powerhouse etc.
3. Submerged Area	Furnish information on area of villages submerged, forestland, agricultural land etc.
4. Approximate period of construction.	
5. Commissioning Date	
6. Annual Generation (Primary Energy, Secondary Energy)	

5B.1. Connection:

1. Point of connection	Furnish single line diagram of proposed connection with the Transmission System
Step up voltage for connection kV	

5B.2. Station Capacity:

1. Total power station capacity MW	State whether development would be carried out in phases and if so furnish details
2. No. of Units and unit size MW.	

5B.3 Generation Unit Data:

1. Operating Head (In Mtr)	Maximum Minimum
----------------------------	--------------------

	Average
2. Turbine	State type and capacity
3. Generator	<ul style="list-style-type: none"> a) Type b) Rating (MVA) c) Terminal Voltage (kV) d) Rated Power Factor e) Reactive Power capability (MVA_r) in the range of 0.95 leading and 0.85 of lagging. f) Short Circuit Ratio g) Direct axis transient reactance (% on rated MVA) h) Direct axis Sub-transient reactance (% on rated MVA) i) Auxiliary Power Requirement
4. Generator – Transformer	<ul style="list-style-type: none"> a) Type b) Rated Capacity (MVA) c) Voltage Ratio HV/LV d) Tap change Range (+ % to - %) e) Percentage Impedance (Positive sequence at Full load rating)

5C Detailed Planning Data (Generation)

5C.1 Thermal Power Stations

I. General:

1. Name of Power Station:
2. No. and capacity of Generating Units (MW):
3. Ratings of all major equipments:
 - (a) Boilers and Major accessories (Steam temperature/pressure)
 - (b) Coal Mill (KW)
 - (c) Feed water Pumps (KW)
 - (d) ID Fans (KW)
 - (e) Turbines

- (f) Alternators
- (g) Generating Unit Transformers (MVA)
- (h) Station Transformers
- 4. Auxiliary Transformers (MVA)
- 5. Single line diagram of Power Station and switchyard.
- 6. Relaying and metering diagram.
- 7. Neutral Grounding of Generating Units.
- 8. Excitation control (type - E.g. Static Excitation System, Fast Brushless)
- 9. Earthing arrangements with earth resistance values.

5C.2. Protection and Metering:

- 1. Full description including settings for all relays and protection systems installed on the generating Unit, Generating Unit Transformer, Auxiliary Transformer and electrical motor of major equipment listed, but not limited to, under section 20.
- 2. Full description including settings for all relays installed on all outgoing circuits from Power Station substation switchyard, tie circuit breakers, incoming circuit breakers.
- 3. Full description of inter-tripping of Breakers at the point or points of Connection with the Transmission System.
- 4. Most probable fault clearance time for electrical faults on the User's system.
- 5. Full description of operational and commercial metering schemes.

5C.3 Switchyard:

- 1. In relation to interconnecting transformers between High Voltage Transmission System and the Generator Transformer High Voltage System:
 - (a) Rated MVA
 - (b) Voltage Ratio
 - (c) Vector Group
 - (d) Positive sequence reactance (maximum, minimum, normal Tap(% on MVA)
 - (e) Positive sequence resistance (maximum, minimum, normal Tap (% on MVA)
 - (f) Zero sequence reactance (% on MVA)
 - (g) Tap changer Range (+ % to - %) and steps

- (h) Type of Tap changer (OFF/ON)
- (i) Details of Reactors, and other circuits connected to tertiary winding of ICT.
- 2. In relation to switchgear including circuit breakers, isolators on all circuits connected to the points of connection:
 - (a) Rated Voltage (KV)
 - (b) Type of Breaker (MOCB/ABCB/SF6)
 - (c) Rated short circuit breaking current (kA) 3 Phase
 - (d) Rated short circuit breaking current (kA) 1 Phase
 - (e) Rated short circuit making current (kA) 3 Phase
 - (f) Rated short circuit making current (kA) 1 Phase
 - (g) Provisions of auto reclosing with details.
- 3. Lightning Arresters, Technical data.
- 4. Communication- Details of PLC equipments installed at points of connections.
- 5. Basic Insulation Level (KVp).
 - (a) Busbar.
 - (b) Switchgear.
 - (c) Transformer Bushings.
 - (d) Transformer windings.

5D. Generating Units: -

5D.1. Parameters of Generating Units:

1. Rated terminal voltage (KV)
2. Rated MVA
3. Rated MW
4. Inertia constant (MW Sec./MVA) of Generator, Exciter and Turbine
5. Short circuit ratio
6. Direct axis synchronous reactance (% on MVA)
7. Direct axis transient reactance (% on MVA)
8. Direct axis sub-transient reactance (% on MVA)
9. Quadrature axis synchronous reactance (% on MVA)
10. Quadrature axis transient reactance (% on MVA)

11. Quadrature axis sub-transient reactance (% on MVA)
12. Direct axis transient open circuit time constant (Sec)
13. Direct axis sub-transient open circuit time constant (Sec)
14. Quadrature axis transient open circuit time constant (Sec)
15. Quadrature axis sub-transient open circuit time constant (Sec)
16. Stator Resistance (Ohm)
17. Stator leakage reactance (Ohm)
18. Stator time constant (Sec)
19. Rated Field current (A)
20. Open Circuit saturation characteristic for various terminal voltages giving the exciting current to achieve the same.
21. Generator Capability Curve

5D.2 Parameters of Excitation control system:

1. Type of Excitation
2. Maximum Field voltage
3. Minimum Field voltage
4. Rated Field voltage
5. Gain Factor
6. FeedBack Strength
7. Time constant for control amplifier
8. Time constant for Exciter
9. Time constant for FeedBack
10. Output voltage of control amplifier
11. Maximum Output voltage of control amplifier
12. Minimum Output voltage of control amplifier
13. Details of excitation loop in Block Diagrams showing transfer functions of individual elements using IEEE symbols along with set values.
14. Dynamic characteristics of over - excitation Limiter
15. Dynamic characteristics of under -excitation Limiter

Note: Using IEEE Committee Report symbols the following parameters shall be furnished: D , A , BS_x , K_a , K_c , K_f , T_a , Y_f , $V_r(\max)$, $V_r(\min)$, S_a , S_b .

5E. Parameters of Governor:

1. Governor average gain (MW/Hz)
2. Speeder motor setting range
3. Time constant of steam or fuel Governor valve
4. Governor valve opening limits.
5. Governor valve rate limits.
6. Time constant of Turbine
7. Governor Block Diagram showing transfer functions of individual elements using IEEE symbols along with set values.

5F. Plant Performance:

1. Daily Demand Profile (Last Year)	Peak and Average in time marked 30 minutes throughout the day.
2. Daily Demand Profile (forecast)	In time marked 30 minutes throughout the day.
3. Units Generated (MU)	
4. Units consumed in Auxiliaries (MU)	
5. Units supplied from system to Auxiliary Load	
6. Seasonal Generation	

5G Operational Parameters:

1. Min. notice required for Synchronizing a Generating Unit from De-synchronization.
2. Min. time between Synchronizing different Generating Units in a Power station.
3. The minimum block load requirements on Synchronizing.
4. Time required for Synchronizing a Generating Unit for the following conditions:
 - (a) Hot

- (b) Warm
 - (c) Cold
5. Maximum Generating Unit loading rate for the following conditions:
- (a) Hot
 - (b) Warm
 - (c) Cold
6. Minimum load without oil support (MW)

5H Hydroelectric Stations:

I. General:

1. Name of Power Station:
2. No. and capacity of Units (MVA)
3. Expected level of Generation
4. Period of Generation (in months) per year
5. Whether the plant is based on water released from dam/canal for irrigation purposes
6. Rating of all major equipments.
 - (a) Turbine (HP):
 - (b) Generators (MVA):
 - (c) Generator Transformers (MVA):
 - (d) Auxiliary Transformers (MVA):
7. Single line diagram of power station and switchyard.
8. Relaying and metering diagram.
 - (a) Neutral grounding of generator.
 - (b) Excitation control.
 - (c) Earthing arrangements with earth resistance values.

II. Reservoir Data:

Salient features:

1. Type of Reservoir: Multipurpose/Power only
2. Operating Table with:

- (i) Area capacity curves,
- (ii) Unit capability at different net heads,
- (iii) FRL/MDDL.

III. **Protection:**

1. Full description including settings for all relays and protection systems installed on the Generating units, generator transformer, Auxiliary transformer and electrical motor of major equipment {included}, but not limited to those listed under General.
2. Full description including settings for all relays installed on all outgoing feeders from Power Station switchyard, tie breakers, and incoming breakers.
3. Full description of inter-tripping of breakers at the point or points of Connection with the Transmission System.
4. Most probable fault clearance time for electrical faults on the User's system.

IV. **Switchyard:**

1. Interconnecting Transformers:

- (a) Rated MVA
- (b) Voltage Ratio
- (c) Vector Group
- (d) Positive sequence reactance for maximum, minimum, normal Tap (% on MVA)
- (e) Positive sequence resistance of maximum, minimum, normal Tap (% on MVA).
- (f) Zero sequence reactance (% on MVA)
- (g) Tap changer Range (+ % to - %) and steps
- (h) Type of Tap changer (OFF/ON)

2. Switchgear (including circuit breakers, Isolators on all circuits connected to the points of connection):

- (a) Rated voltage (KV)
- (b) Type of Breaker (MOCB/ABCB/SF6)
- (c) Rated short circuit breaking current (KA) 3 Phase.
- (d) Rated short circuit breaking current (KA) 1 Phase.
- (e) Rated short circuit making current (KA) 3 Phase.

- (f) Rated short circuit making current (KA) 1 Phase.
 - (g) Provisions of auto reclosing with details.
 - (h) Details of Instrument Transformers.
3. Lightning Arresters, Technical data.
4. Communications: Details of communications equipment installed at points of connections.
5. Basic Insulation level (KV):
- (a) Bus bar
 - (b) Switchgear
 - (c) Transformer Bushings
 - (d) Transformer Windings
6. Generating Units:
- i. Parameters of Generator:
 - (a) Rated terminal voltage (KV)
 - (b) Rated MVA
 - (c) Rated MW
 - (d) Inertia constants (MW Sec./MVA) of Generator, Exciter and Turbines
 - (e) Short circuit ratio
 - (f) Direct axis synchronous reactance. (% on MVA)
 - (g) Direct axis transient reactance. (% on MVA)
 - (h) Direct axis sub-transient reactance (% on MVA)
 - (i) Quadrature axis synchronous reactance (% on MVA)
 - (j) Quadrature axis sub-transient reactance (% on MVA)
 - (k) Direct axis transient open circuit time constant (SEC)
 - (l) Direct axis sub-transient open circuit time constant (SEC)
 - (m) Stator Resistance (Ohm)
 - (n) Stator leakage reactance (Ohm)
 - (o) Stator time constant (Sec)
 - (p) Rated Field current (A)

- (q) Open Circuit saturation characteristics of the Generator for various terminal voltages giving the compounding current to achieve this.
 - (r) Generator Capability Curve
- ii. Type of Turbine:
- (a) Operating Head (Mtr.)
 - (b) Discharge with Full Gate Opening (Cumecs)
 - (c) Speed Rise on total Load throw off (%)
- iii. Parameters of Excitation Control system
(AS APPLICABLE TO THERMAL POWER STATIONS)
- iv. Parameters of Governor
(AS APPLICABLE TO THERMAL POWER STATIONS)
7. Operational parameters:
- (a) Minimum notice required for Synchronizing a Generating Unit from De-synchronization.
 - (b) Minimum time between Synchronizing different Generating Units in a power station.
 - (c) Minimum block load requirements on Synchronizing.

5I Planning Data Generation

(For submission on request by Transmission Licensee)

5I.1 For Thermal Power Stations:

5I.1.1 General:

1. Detailed Project report.
2. Status Report:
 - (a) Land

- (b) Fuel type
 - (c) Cooling Method
 - (d) Environmental clearance
 - (e) Rehabilitation of displaced persons.
3. Approval by Nigeria Electricity Regulatory Commission
 4. Financial tie-up.

5I.1.2 Connection:

1. Report of studies of parallel operation with Transmission System:
 - (a) Load flow studies
 - (b) Stability studies
 - (c) Short Circuit studies
2. Proposed connection with Transmission System:
 - (a) Voltage
 - (b) No. of circuits
 - (c) Point of connection

5I.2. Hydroelectric Power Stations:

5I.2.1 General:

1. Detailed Project Report
2. Status Report
 - (a) Topographical survey
 - (b) Geological Survey
 - (c) Land
 - (d) Environmental clearance
 - (e) Rehabilitation of displaced persons
3. Approval by Nigeria Electricity Regulatory Commission
4. Financial Tie-up.

5I.2.2 Connection:

1. Reports of studies for parallel operation with Transysco System.
 - (a) Load flow studies
 - (b) Short Circuit studies
 - (c) Stability studies
2. Proposed Connection with Transmission System:
 - (a) Voltage
 - (b) No. of Circuits.
 - (c) Point of connection.

1. Loads drawn at points of connection:
2. Details of loads fed at HV : Give name of consumer, voltage of supply, contract demand and name of Grid Sub-station from which line is drawn, length of EHT line from Grid Sub-station to consumer's premises.

V. Demand Data (For all Loads 1 MW and above):

1. Type of load: State whether furnace loads, rolling mills, traction loads, other industrial loads, pumping loads etc.
2. Rated voltage:
3. Electrical loading of equipment: State number and size of motors, types of drive and control arrangements.
4. Sensitivity of load to voltage and frequency of supply:
5. Maximum harmonic content of load:
6. Average and maximum phase unbalance of load:
7. Nearest sub-station from which load is to be fed:
8. Location map to scale: Map shall show the location of load with reference to lines and sub-stations in the vicinity.

VI. Load Forecast Data:

1. Peak load and energy forecast for each category of loads for each of the succeeding 5 years.
2. Details of methodology and assumptions on which forecasts are based.
3. If supply is received from more than one sub-station, the sub-station breaks up of peak load and energy projection for each category of loads for each of the succeeding 5 years along with estimated daily load curve.
4. Details of load 1MW and above.
 - (a) Name of prospective consumer.

- (b) Location and nature of load/complex.
- (c) Sub-station from which to be fed.
- (d) Voltage of supply.
- (e) Phasing of load.

6B. Detailed Planning Data (Distribution)

6B.1 General:

1. Distribution map (To scale). Showing all lines up to 11 KV and sub-stations belonging to the Licensee.
2. Single line diagram of distribution system (showing distribution lines from points of connection with transmission system 132/33 KV Sub-station, 33/11 KV sub-station, consumer bus if fed directly from Transmission System)
3. Numbering and nomenclature of lines and sub-stations (Identified with feeding Grid sub-stations of the Transmission System and concerned 33/11 KV sub-station of supplier).
4. Monitoring of Transmission and Distribution Losses (Methods adopted for reduction of losses to be stated).

6B.2 Connection:

1. Points of connection (Furnish details of existing arrangement of Connection)
2. Details of metering of points of connection.

6B.3 Loads:

1. Connected Load (Category-wise) - Furnish consumer details, No. of consumers category-wise details of loads 1 MW and above)
2. Information on diversity of load and coincidence factor.
3. Daily demand profile (current and forecast) on each 33kV/11kV sub-station.
4. Cumulative Demand Profile of Distribution (current and forecast)

6B.4 Detailed Planning Data (Distribution)

(For submission on request by the Transmission Licensee)

I. General:

1. Detailed Project Report (For new and system improvement schemes)
2. Status Report
 - (a) Load Survey
 - (b) Load forecast for next five years
3. Single Line Diagram showing proposed new lines and Sub-stations

II. Connection:

1. Points of connection as applied for
 - (a) New
 - (b) Upgrading existing connection
2. Changes in metering at points of connection

III. Loads:

1. Details of loads as per the forecast in next 5 years
2. Distribution of loads 33/11 kV Sub-station wise projected for next 5 years
3. Details of major loads of 1 MW and above to be contracted for next 5 years

IV. Improvement Schemes for reduction of Sub-transmission and Distribution Losses:

1. Statement of estimated Sub-transmission and Distribution losses for next five years
2. Brief indication of improvement scheme for reduction of losses (excerpts from Detailed Project Report)
 - (a) New lines
 - (b) Upgrading of lines
 - (c) New Sub-station/Upgrading of Sub-stations
 - (d) Rearrangement of loads
 - (e) Installation of capacitors.



APPENDIX 7 – NETWORK EXPANSION PLANNING DATA

REQUIREMENTS:

To enable the Transysco to discharge its responsibilities under its Transmission Licence Conditions by conducting System Studies and preparation of perspective plans for Demand, Generation and Transmission Network expansion as detailed under the Grid Code, all Users of the Transmission Network shall furnish all the data to the Transysco from time to time detailed below under Data Registration Requirement of Sections 15 and 16.

[In pursuance of Sections 15 and 16 of the Grid Code, items in this Appendix must be included in the yearly 5 year planning study report of Transysco and provided to Users (e.g. Generating Companies, Discos) on an annual basis.]

7A. Standard Planning Data (Transmission)

Note: - The compilation of the data is the internal matter of the Licensee, and as such the Licensee shall make arrangements for getting the required data from different Departments of the Licensee to up-date its standard planning Data in the format given below:

1. Name of the line: (Indicating Power stations and Sub-stations to be connected)
2. Voltage of line (KV):
3. No. of Circuits:
4. Route length (Circuit KM):
5. Conductor sizes:
6. Line parameters (PU on 100 MVA base or ohmic values):
 - (a) Resistance/KM
 - (b) Inductive Reactance /KM
 - (c) Suceptance/KM
7. Approximate power flow MW & MVAr:
8. Terrain of route: Give information regarding nature of terrain i.e., forestland, fallow land, agricultural and river basin, hill slope etc.
9. Route Map (to scale): Furnish topographical map showing the

- proposed route showing existing power lines and telecommunication lines
10. Purpose of connection: Reference to scheme, wheeling to other States etc.
11. Approximate period of construction:

7B Detailed System Data (Transmission)

Note: The compilation of the data is the internal matter of Transysco, and as such, it shall make arrangements for getting the required data from different departments of its organization and update to its Standard Planning Data in the format given below.

7B.1 General:

- (a) Single line diagram of the User's system from 132 KV bus and above at grid sub-station:
- (b) Name of sub-station
- (c) Power Station connected
- (d) Number and length of Circuits
- (e) Interconnecting transformers
- (f) Sub-station bus layouts
- (g) Power Transformers
- (h) Reactive compensation equipment
 - 1. The details of capacitors installed
 - 2. Additional capacitors to be commissioned along with additional loads.
- (i) Lightning Arresters
- (j) Bus and/or Line Reactors

7B.2 Sub-station layout diagrams showing:

- (a) Bus bar layouts
- (b) Electrical circuitry, lines, cables, transformers, switchgear etc
- (c) Phasing arrangements
- (d) Earthing arrangements
- (e) Switching facilities and interlocking arrangements
- (f) Operating voltages
- (g) Numbering and nomenclature
 - i. Transformers
 - ii. Circuits
 - iii. Circuit Breakers
 - iv. Isolating switches

7B.3.1 Line parameters: (For all Circuits)

- (a) Designation of line
- (b) Length of line (KM)
- (c) No. of circuits, size and type of conductor, thermal rating
- (d) Per Circuit values
 - i. Operating voltage (KV)
 - ii. Positive phase sequence reactance - ohms/KM
 - iii. Positive phase sequence resistance - ohms/KM
 - iv. Positive phase sequence susceptance - mhos/KM
 - v. Zero phase sequence reactance - ohms/KM
 - vi. Zero phase sequence resistance - ohms/KM
 - vii. Zero Phase sequence susceptance - mhos/KM

7B.3.2 Transformer parameters: (For all transformers)

- (a) Rated MVA
- (b) Voltage Ratio
- (c) Vector Group
- (d) Positive sequence reactance on rated MVA base (Max., min. & normal)

- (e) Positive sequence resistance on rated MVA base (max., min. & Normal)
- (f) Zero sequence reactance on rated MVA base
- (g) Tap change range (+% to -%) and steps
- (h) Details of tap changer (OFF/ON)
- (i) Neutral Grounding Transformer/Resistor Values

7B.3.3 Equipment Details: (For all Sub-stations):

- (a) Circuit Breakers
- (b) Isolating switches
- (c) Current Transformers
- (d) Potential Transformers
- (e) Lightning Arresters

7B.3.4 Relaying and metering:

- (a) Relay protection installed for all transformers and Feeders along with their settings and level of co-ordination with other users.
- (b) Metering Details:

7B.4 System studies:

- (a) Load flow studies (Peak and lean load for maximum Hydro and maximum Thermal Generation)
- (b) Transient stability studies for 3 Ph. Fault in critical lines, relay reclosing for 132 KV Lines.
- (c) Dynamic stability studies
- (d) Short circuit studies (3 Ph. and single Ph. to earth)
- (e) Transmission and Distribution losses in the system.

7B.4.1 Demand Data: (For all sub-stations)

- (a) Demand Profile (Peak and lean load)
 - i. Current
 - ii. Forecast for next 5 years

7B.4.2 Reactive Compensation equipment:

- (a) Type of equipment (fixed or variable)
- (b) Capacities and/or inductive rating (Voltage and MVAR) or its operating range.
- (c) Details of control
- (d) Point of Connection to the system.

7B.5 Detailed Planning Data (Transmission)

(To be submitted on request by the Transmission Licensee to Users of the Transmission System)

7B.5.1 General:

1. Detailed Project Report (For new and System Improvement Schemes)
2. Status Report
3. Line:
 - (a) Route Survey
 - (b) Forest Clearance
4. Sub-Stations
 - (a) Land
 - (b) Environmental Clearance
 - (c) Financial Tie-up

7B.5.2 Connection:

1. Single Line Diagram showing position of connection
2. Sub-station layout diagram
 - (a) New

- (b) Addition and Alteration
- 3. Revised system studies with changed parameters
- 4. Point of Connection
 - (a) Voltage
 - (b) Length of circuit
 - (c) Circuit parameters
 - (d) PLCC facilities
 - (e) Relaying with inter tripping arrangements to inter trip system breaker at point of connection to isolate on fault
 - (f) Metering at point of connection.

Appendix 8: Grid Code Review Panel

8A.1 The Nigerian Electricity Regulatory Commission (NERC) shall establish the Grid Code Review Panel. The Panel shall be responsible for improving and developing the Code through regular review, consultation, research and other methodologies found appropriate from time to time. The funding and maintenance of the Panel shall be the responsibility of Transysco, including the location of the Panel's secretariat.

The Panel shall be a standing body to carry out the functions referred to in paragraph 8A.2.

8A.2 The Grid Code Review Panel shall:

- i. keep the Grid Code and its working under review;
- ii. review all suggestions for amendments to the Grid Code which NERC or any User or Transysco may wish to submit for consideration by the Panel from time to time;
- iii. publish recommendations as to amendments to the Grid Code that Transysco or the Panel feels are necessary or desirable and the reasons for the recommendations;
- iv. issue guidance in relation to the Grid Code and its implementation, performance and interpretation when asked to do so by any User;
- v. consider what changes are necessary to the Grid Code arising out of any unforeseen circumstances referred to it by Transysco; and
- vi. consider and identify changes to the Grid Code to remove unnecessary section(s) or clause(s) that are of irrelevant to the effective operation of the Nigeria Transmission Network

8A.3 The Panel shall consist of:

- i. a Chairman and up to 4 members appointed by Transysco from Network , System , Market and Safety Operations of Transysco;
- ii. a person appointed by the Nigerian Electricity Regulatory Commission; and
- iii. 3 persons representing Generating Companies one of which must represent hydro power stations;
- iv. 3 persons representing the Distribution Companies;
- v. a person representing the Rural Electrification Agency;
- vi. a person representing Consumers with maximum demand greater than or equal to 1MW

each of the Panel member shall be appointed by their respective industry sector pursuant to the rules issued by the Panel in 8A.4.

8A.4 The Panel shall establish and comply at all times with its own rules and procedures relating to the conduct of its business, which shall be approved by NERC. Meetings of the Panel shall be held at regular intervals and at least every month at such time and place as the Panel shall decide.

8A.5 The Panel shall consult in writing all Industry Stakeholders and Operators which are liable to be affected in relation to all proposed amendments to the Grid Code and shall review and discuss all proposed amendments and comments to the Grid Code prior to coming up with recommendations to amending the Grid Code.

8A.6 The Panel through Transysco shall establish (and, where appropriate, revise from time to time) joint working arrangements with industry stakeholders or operators to facilitate the identification, coordination, making and implementation of change to their operations consequent on an amendment to the Grid Code in a full and timely manner. These working arrangements shall be such as enable development and evaluation of proposed amendments to the Grid Code, how operators will proceed in a full and timely manner to changes to their operations consequent to an amendment to the Grid Code to be made and given effect wherever possible (subject to any necessary consent of the Nigerian Electricity Regulatory Commission) at the same time as such approved amendment is made and given effect.

Appendix 8: Civil Emergencies

Upon the declaration of civil emergency affecting the production, transportation and consumption of electrical power by competent authority in Nigeria, it is the obligation on the Transysco to prepare and maintain plans for mitigating the effects of any civil emergency and fuel security shortage situation, which may occur in accordance with the Electricity Supply Emergency directive issued by the Industry Regulator. That directive shall describes the steps which authority might take to deal with an electricity production and supply emergency situation and sets down the actions which Companies in the Electricity Supply Industry should plan to take and which may be needed or required in order to deal with such an emergency.

In an electricity emergency it may become necessary to restrict User's Demand for and consumption of electricity and may be achieved by one or more of the following methods:

- a) Appeals by the Industry Regulator to the public for voluntary restraint
- b) The issue of order(s) under competent Nigeria Authority requiring restrictions on consumption by industry, commerce and other users deem appropriate.
- c) The issue of order(s) under competent Nigeria Authority requiring rotating disconnections and associated restrictions.

In the event that the Industry Regulator issues directions to Transysco to implement rotating disconnections, the Transysco will establish an Emergency Coordinating Center and as soon as possible establish communications with such relevant Users as is necessary to ensure operational liaison. The plans to be implemented will be similar or separate from the schemes outlined in Section 12 of the Grid Code.

The plans make provision for the need to maintain supply, so far as practicable, to consumers in protected categories. For the purpose of the Grid Code Security installations, Communication Facilities and Hospitals and other designated Facilities deem appropriate by competent Nigeria Authority shall be deemed to be protected Facility in accordance with the provisions of the Civil Emergency Order.

